

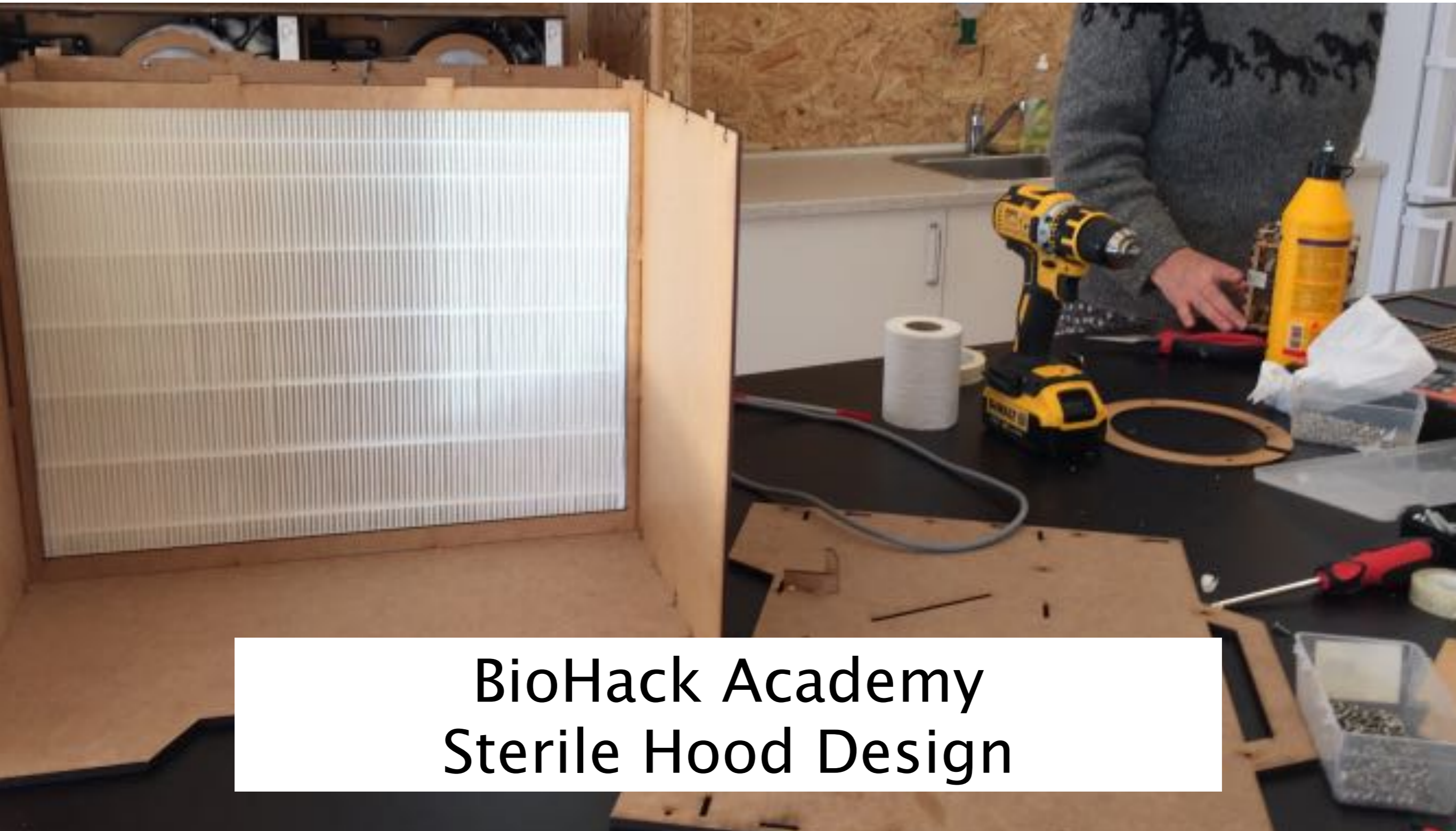

**waag society**

*institute for art, science and technology*



**BioHack Academy  
Sterile Hood Design**



Working sterile

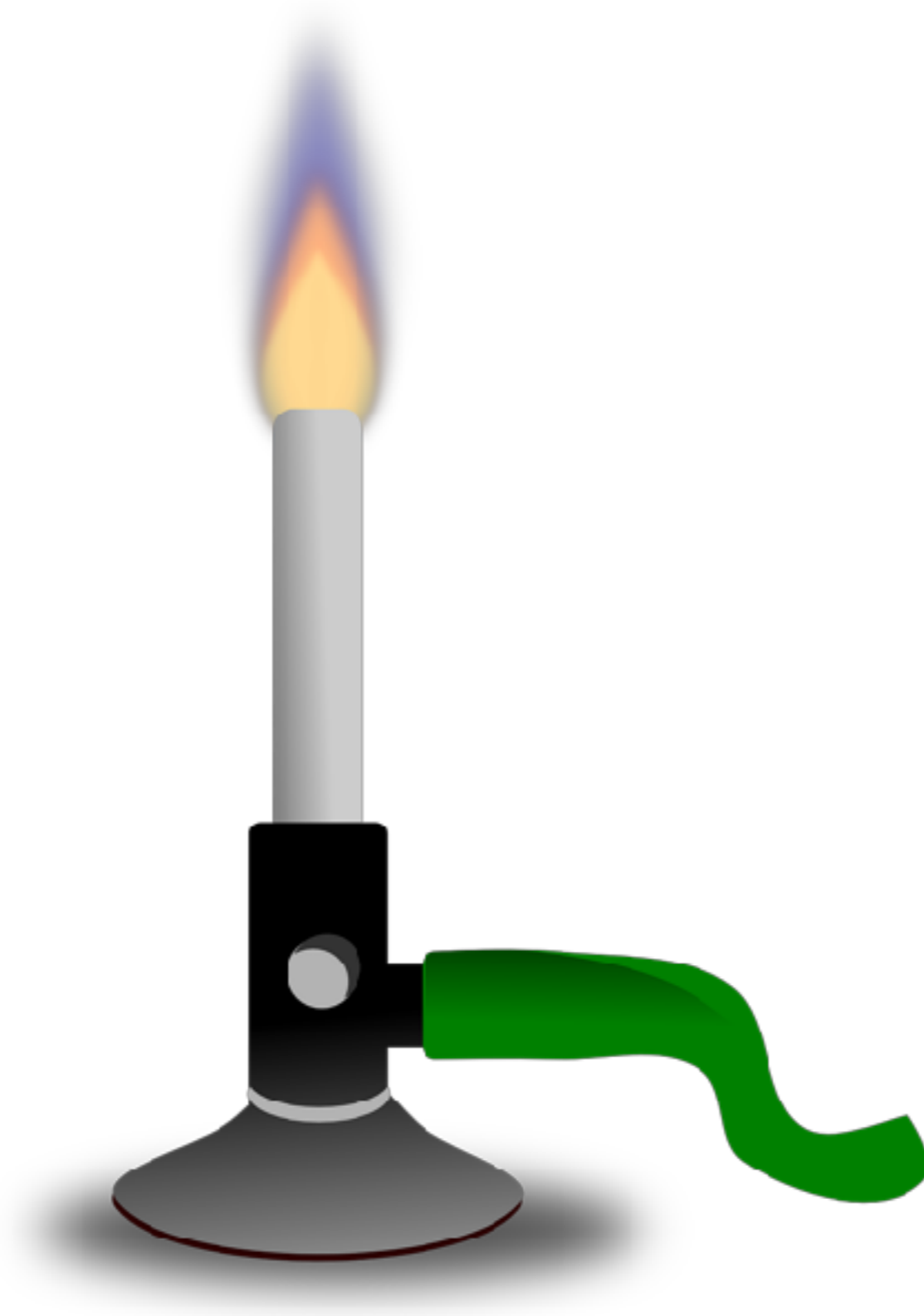



# Sterile hoods



Public Domain



Rudolph Simon - CC-BY-SA 3.0



José Eugenio Gómez Rodríguez - CC-BY-SA 2.0

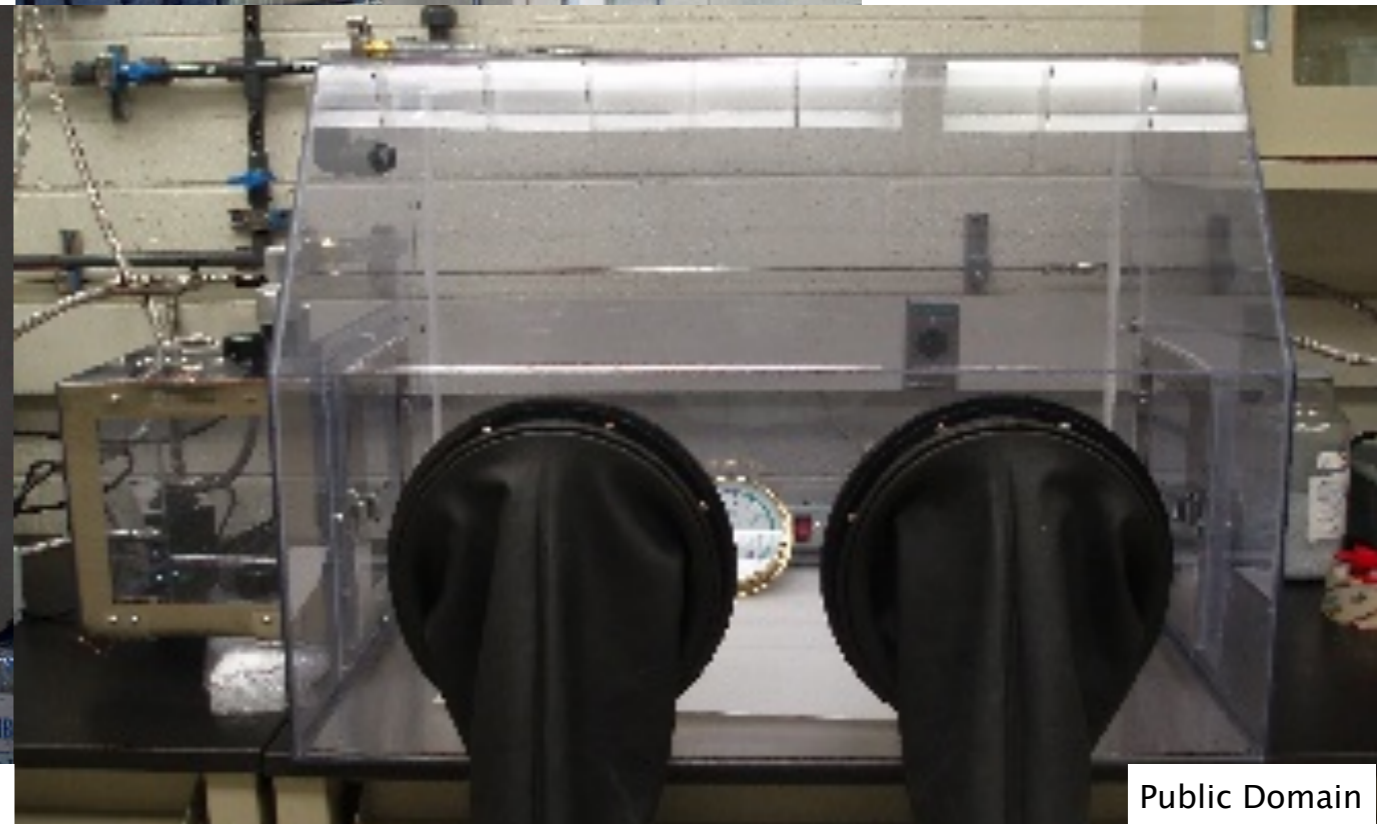

Public Domain



# Components

- Pre filter
- Fan
- HEPA Filter
- Minimal air flow of 0.5 m / second

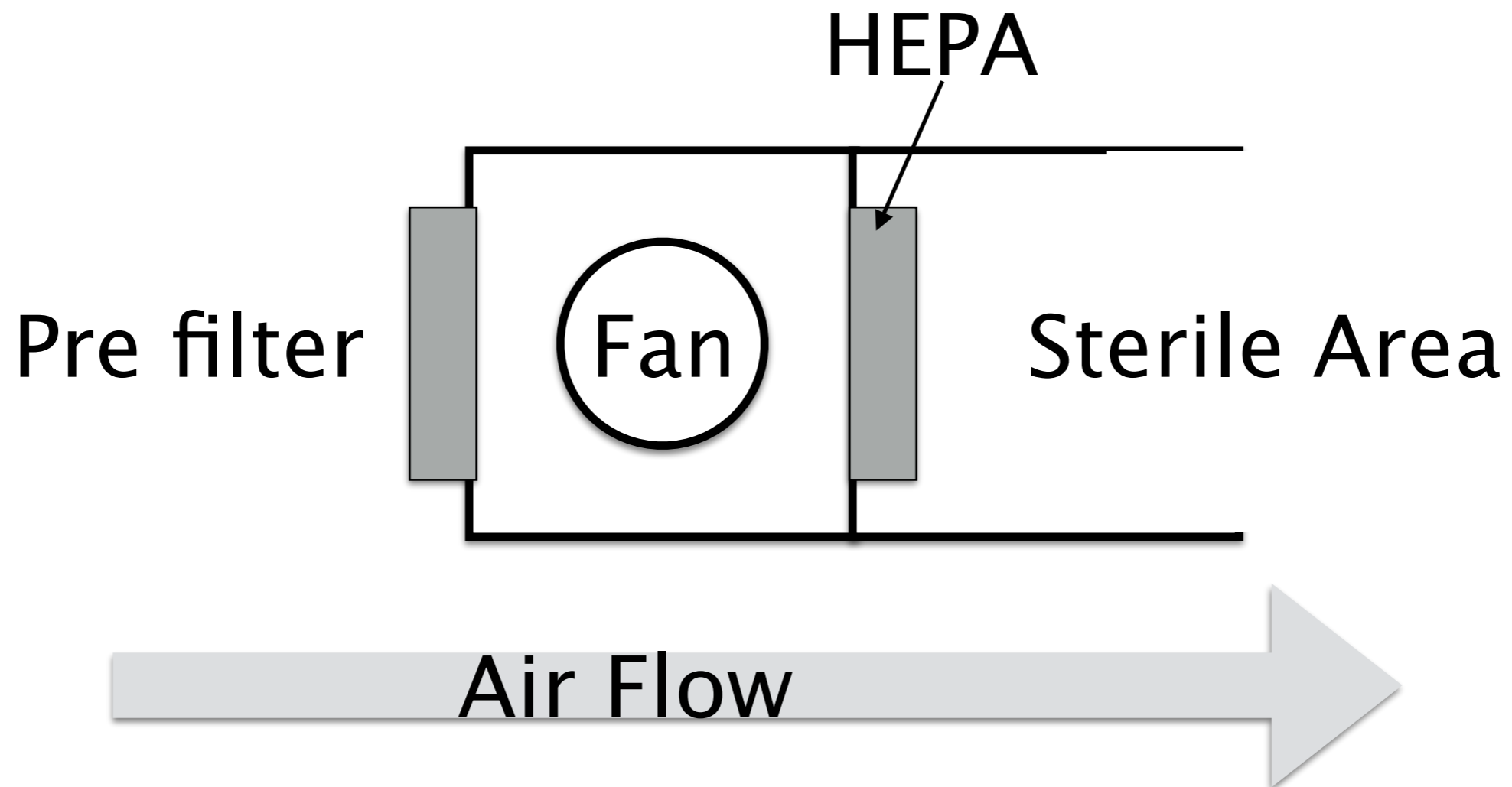



# Horizontal vs Vertical airflow

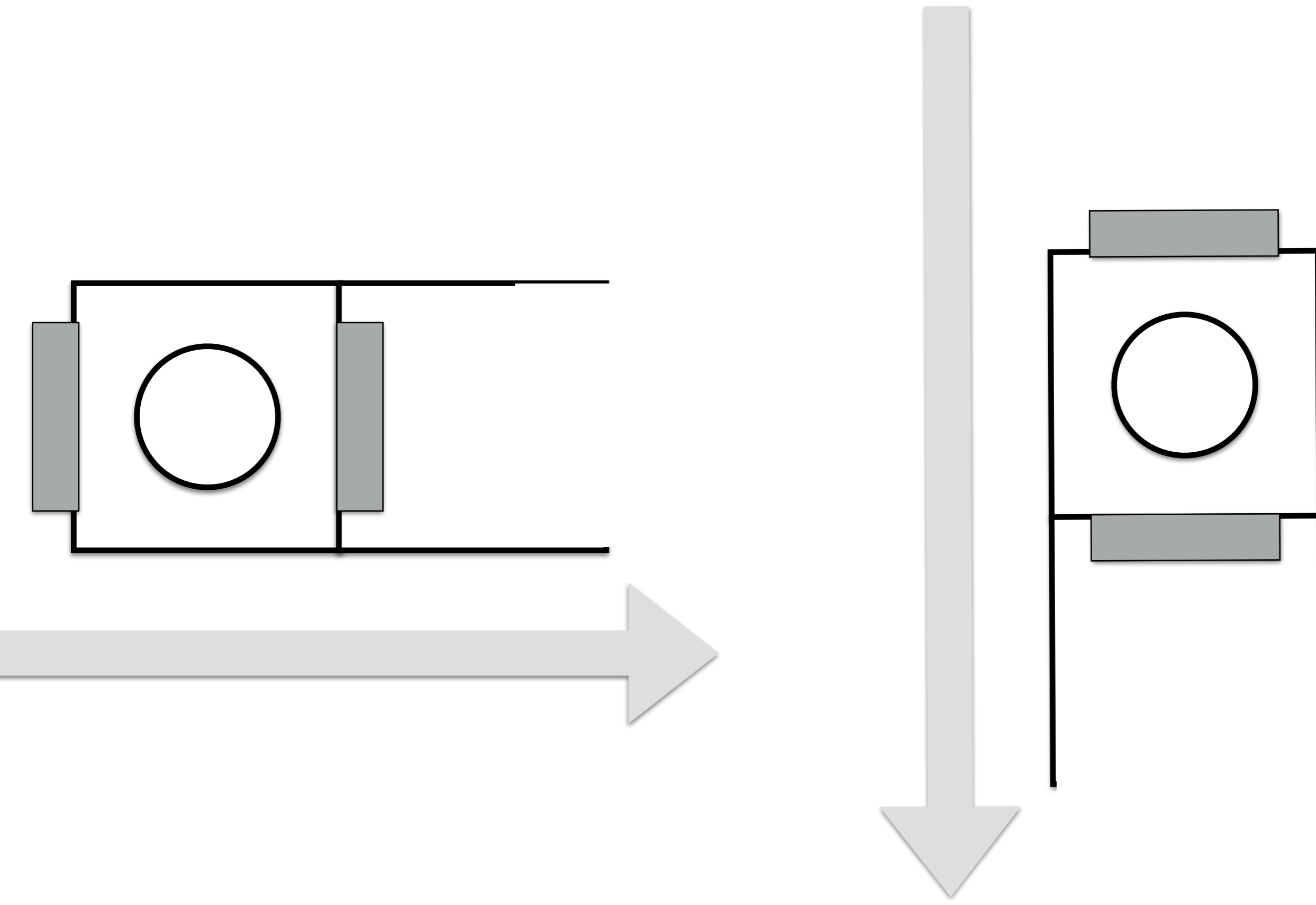



# BioHack Academy 1 Design

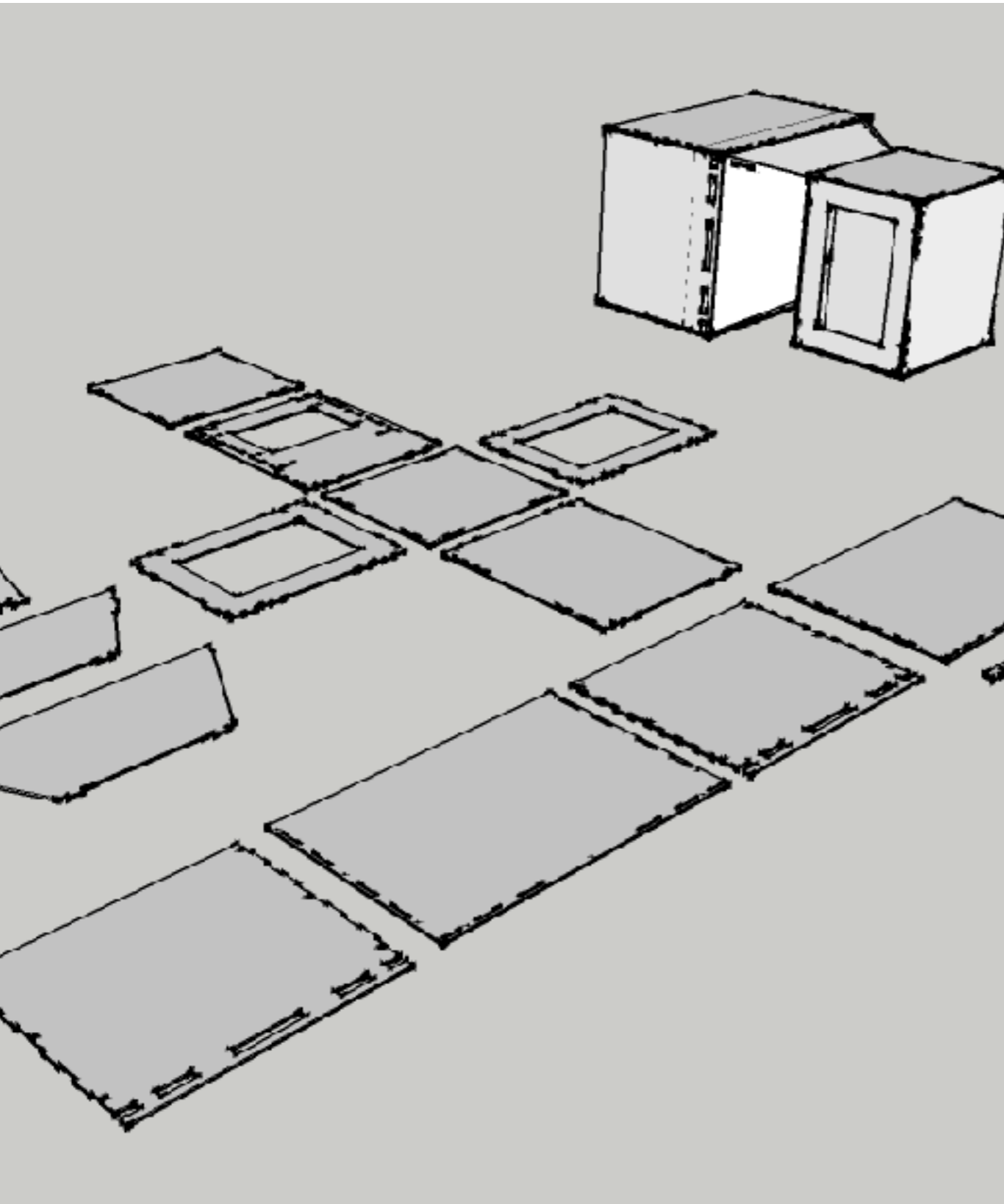



# BioHack Academy 2 Design

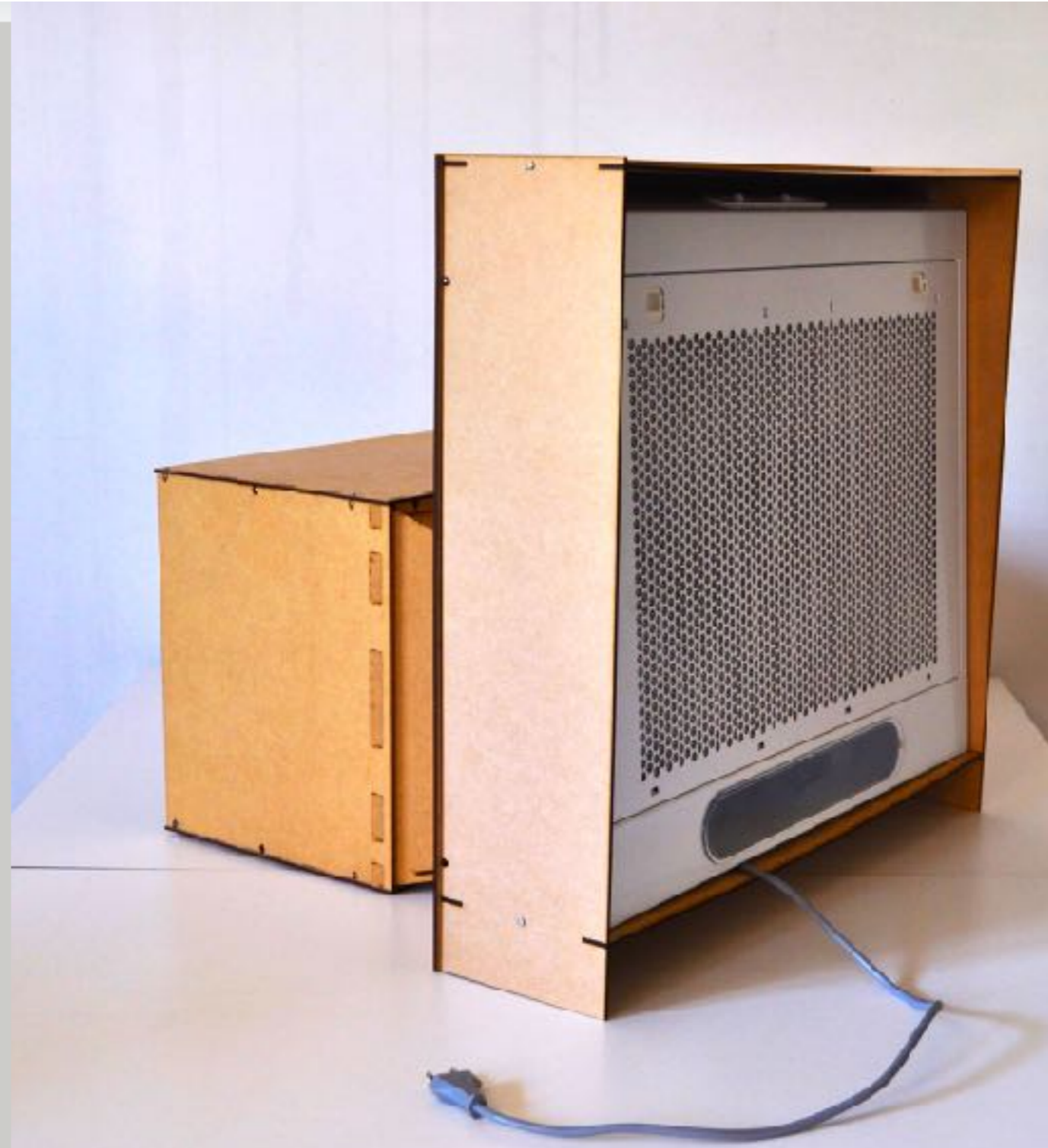
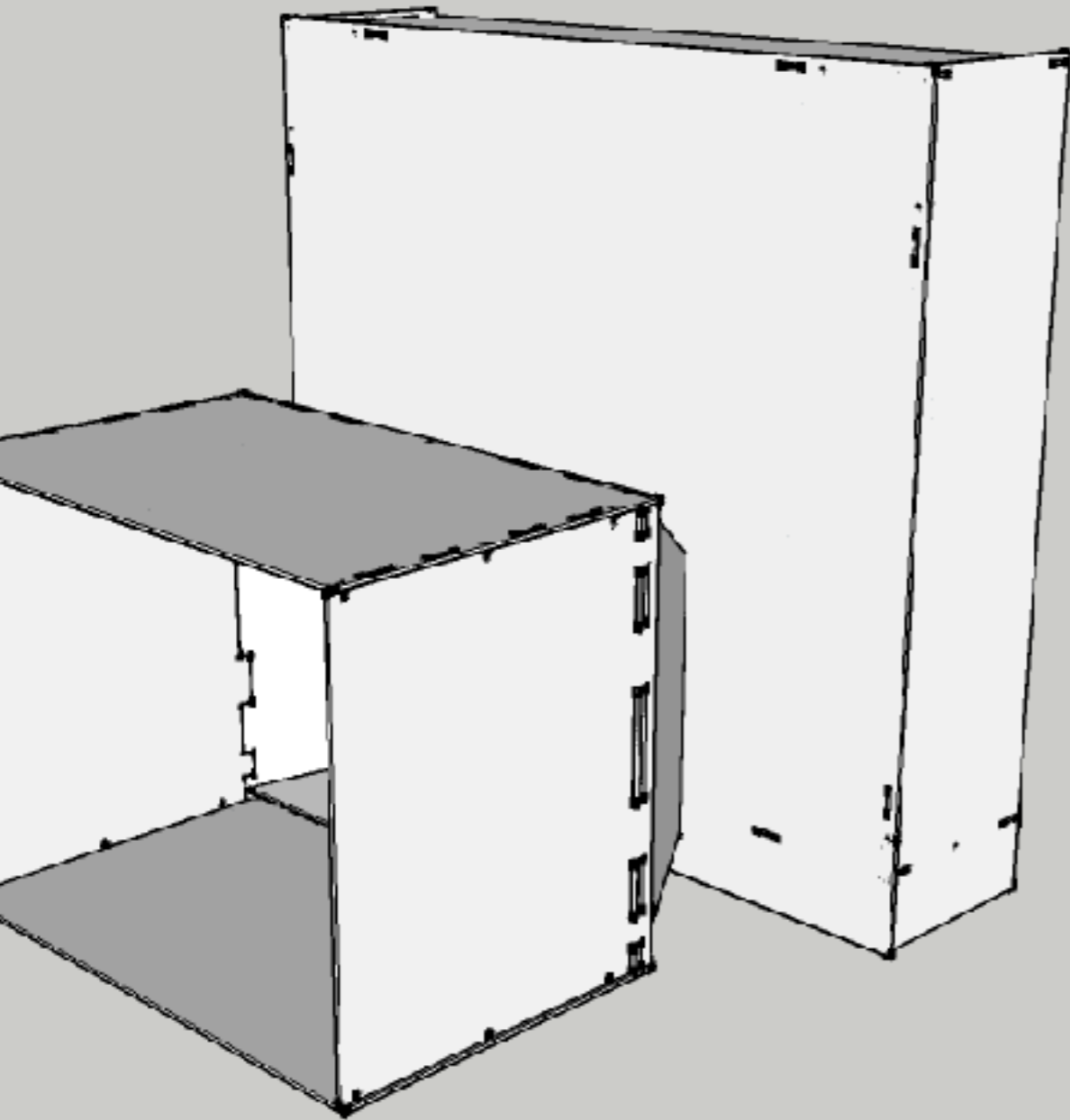



# BioHack Academy 3-current Design

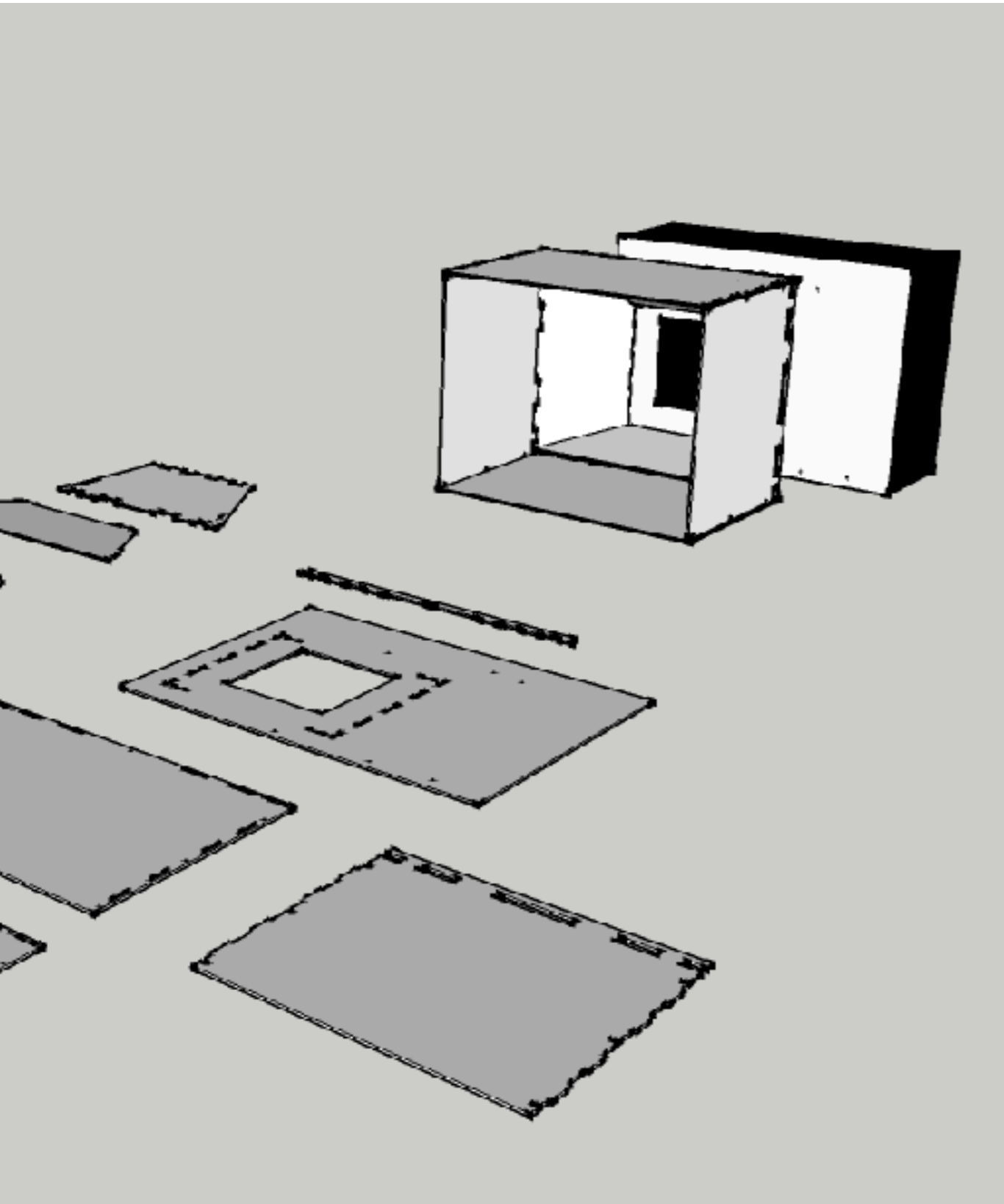





# HEPA filter

- Fellowes office air filter
- 0.3 micron pores
- 99.97% filtering
- H14 class
  - EN1822 standard
- dimensions:  
0.41m, 0.32m





# Blower

- Calculate the airflow
- Needed:
  - $0.41 \times 0.32 \times 0.5 =$
  - 0.0656
  - cubic meter / second
- 236.16
- cubic meter / hour
- We choose a blower with  $\sim 250$  cubic meter / hour



IKEA

\* 1 cubic feet per minute (CFM) = 1.6990 m<sup>3</sup>/h



# Test results

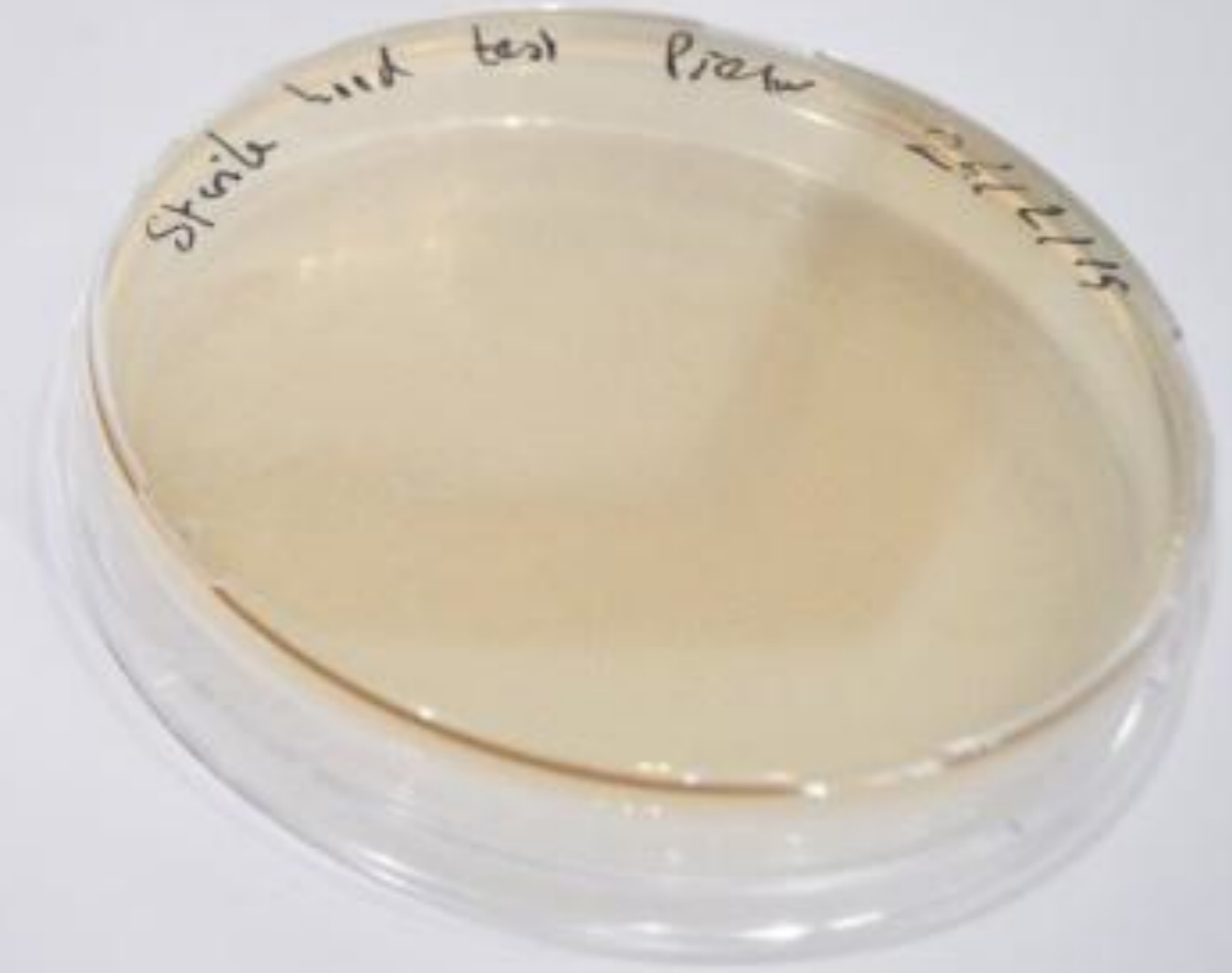



# DIY sterile hood

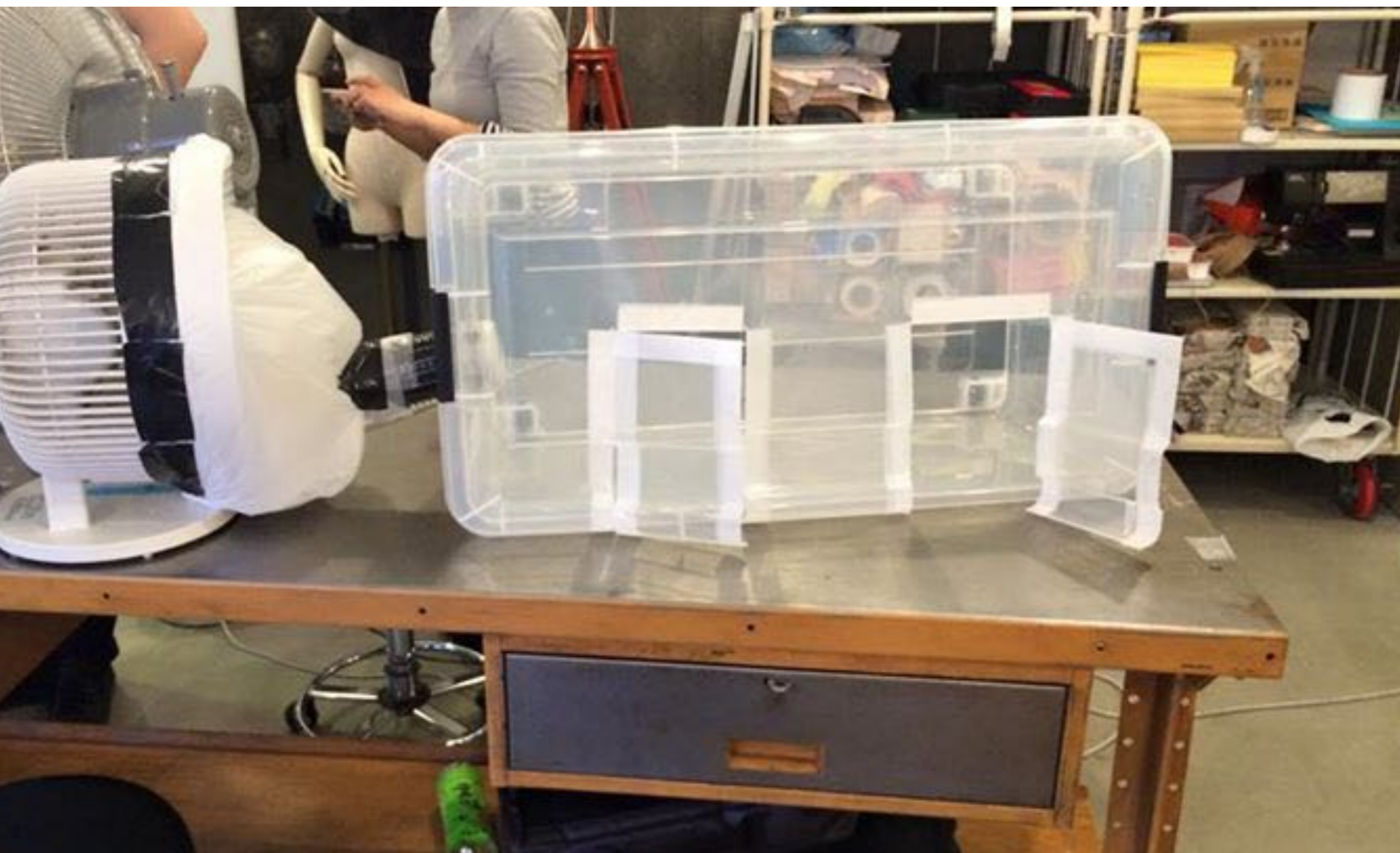



# This week's practicals

- Lab tour
- SketchUp modeling
- Inkscape vector modeling
- Lasercut introduction

## Assignments

- As a group: define “Biohacking” together
- Design your own tube rack
- Introduce yourself on the **BioHack Academy Forum**



**some  
rights  
reserved**